

Silicon PNP Power Transistors

2SB1098

DESCRIPTION

- With TO-220F package
- Complement to type 2SD1589
- DARLINGTON
- High DC current gain

APPLICATIONS

- Low speed switching industrial use
- Low frequency power amplifier

PINNING

PIN	DESCRIPTION
1	Emitter
2	Collector
3	Base

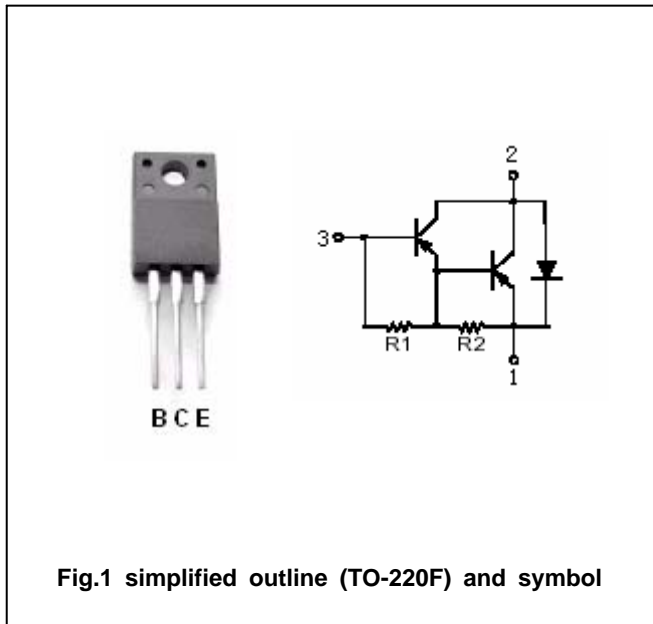

Fig.1 simplified outline (TO-220F) and symbol

Absolute maximum ratings (Ta=25)

SYMBOL	PARAMETER	CONDITIONS	MAX	UNIT
V_{CBO}	Collector-base voltage	Open emitter	-100	V
V_{CEO}	Collector-emitter voltage	Open base	-100	V
V_{EBO}	Emitter-base voltage	Open collector	-7	V
I_C	Collector current		-5	A
I_{CM}	Collector current-peak		-8	A
I_B	Base current		-0.5	A
P_C	Collector dissipation	$T_a=25$	2	W
		$T_C=25$	20	
T_j	Junction temperature		150	
T_{stg}	Storage temperature		-55~150	

Silicon PNP Power Transistors

2SB1098

CHARACTERISTICS

 $T_j=25$ unless otherwise specified

SYMBOL	PARAMETER	CONDITIONS	MIN	TYP.	MAX	UNIT
V_{CEsat}	Collector-emitter saturation voltage	$I_C=-3A; I_B=-3mA$			-1.5	V
V_{BEsat}	Base-emitter saturation voltage	$I_C=-3A; I_B=-3mA$			-2.0	V
I_{CBO}	Collector cut-off current	$V_{CB}=-100V; I_E=0$			-1	μA
I_{EBO}	Emitter cut-off current	$V_{EB}=-5V; I_C=0$			-3	mA
h_{FE-1}	DC current gain	$I_C=-3A; V_{CE}=-2V$	2000		15000	
h_{FE-2}	DC current gain	$I_C=-5A; V_{CE}=-2V$	500			

Switching times

t_{on}	Turn-on time	$I_C=-3A; I_{B1}=-I_{B2}=-3mA$ $R_L=17\ \Omega; V_{CC}=-50V;$		0.5		μs
t_s	Storage time			1		μs
t_f	Fall time			1		μs

◆ h_{FE-1} Classifications

R	O	Y
2000-5000	3000-7000	5000-15000

Silicon PNP Power Transistors

2SB1098

PACKAGE OUTLINE

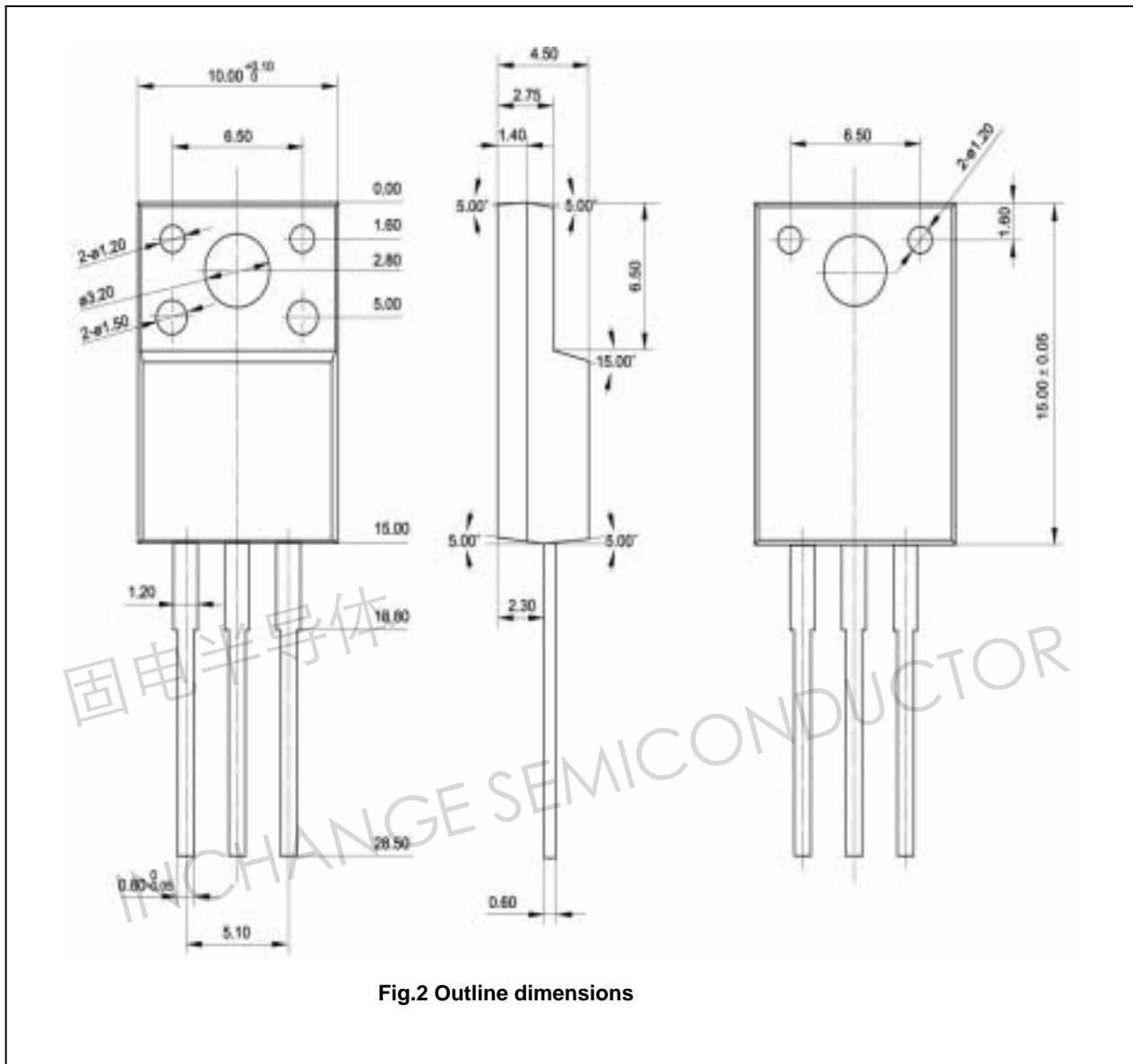

Fig.2 Outline dimensions